

ELOCS DATASHEET

EasiLinc overcurrent protection module

For feeder and bus protection, with or without reclosing



- Perfect for retrofit or new construction projects
- Minimal complexity, maximum performance
- Applications need fewer than 30 customer settings
- No logic settings required
- Event recording, SER, load profiling, and voltage disturbance recording functions active and configured
- Use in 19" equipment rack or panel cutout
- SEL-351S-7 Relay and all test-switches mounted & wired
- For utility and industrial feeder applications

The ELOCS protection module

The EasiLinc ELOCS protection module simplifies your use of microprocessor-based relays for feeder protection. The module includes an SEL-351S-7 Relay and appropriate test switches. These devices are pre-wired and installed in a mounting panel suitable for a 19" equipment rack or switchgear panel cutout. Also included are all the AC and DC application schematics you need to generate final construction prints quickly for your installation. The real time-saver is in the relay settings. Setting the ELOCS protection module is different from any microprocessor-based relay application you have faced before.

EasiLinc Setting Transfer Software contains a library of application setting files that configure most of the relay settings for each application. Application setting files enable and configure the best features of the SEL-351S-7 Relay, leaving only the final protection settings for you. Typical applications require fewer than 30 user settings.

Set the new relay using protection and reclosing concepts that you are familiar with, without learning any relay control commands or logic definition languages.

The EasiLinc ELOCS application setting files:

- Predefine output contact and control input functions.
- Enable event reporting, SER, load profiling, and voltage disturbance recording functions.
- Prepare the relay for substation automation using EasiLinc ELCOM communication modules, ELHMI interface and ELPAGE paging modules.
- Enable or disable reclosing, as your application requires.
- Support fast-bus tripping or zone-interlock bus protection schemes, when required.

Using the ELOCS, you:

- Reduce engineering costs by reducing the relay setting count.
- Reduce electrical design costs by using the provided AC and DC schematics.
- Reduce installation and commissioning costs with pre-wired and pre-tested modules.
- Reduce substation automation costs by using the standard control interface.

- Standardize your design, installation, operation, and maintenance procedures.
- Obtain the accuracy, reliability, and availability benefits of a high performance relay.
- Support accelerated deployment schedules by taking advantage of included design documents.

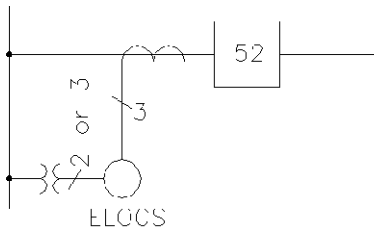

Product applications

- Feeder overcurrent protection
- Simple reclosing
- Fast bus trip output

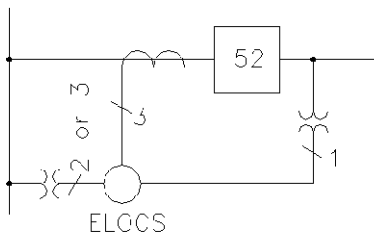

- Feeder overcurrent protection
- Supervised reclosing
- Fast bus trip output

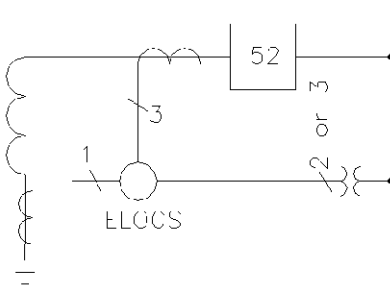

- Bus main breaker protection
- Transformer neutral overcurrent
- Fast bus tripping (optional)

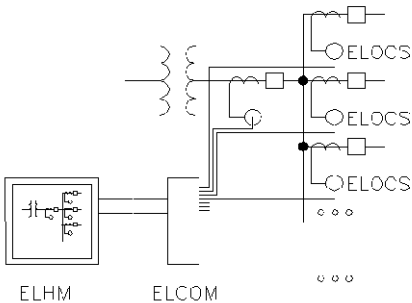

- Substation communication architecture using EasiLinc modules
- Architecture may be extended to central office locations
- Modular concept supports multi-stage projects
- Advanced notification solutions, including paging and e-mail are also available

SEL- 351S Relay major features

- Phase, residual and neutral instantaneous and time-overcurrent protection elements
- Adaptive phase overcurrent elements permit the relay to perform dependably in plant applications where fault currents can be very high
- Reclosing with up to four shots
- Support for four-wire wye or three-wire open delta voltage measurement
- Line-side voltage input for synch-check supervised and voltage-supervised reclosing
- Accurate metering functions for current, voltage, real and reactive power, frequency, DC battery voltage, demand, and energy
- Front-panel operator controls to enable/disable reclosing, enable/disable ground overcurrent protection, trip and close the circuit breaker
- Front-Panel LCD display indicates metered values and text messages of relay, breaker, and alarm conditions
- Load profile function that stores critical feeder data every 15 minutes for later retrieval and analysis
- Event reporting that automatically captures and stores 23 most recent eleven-cycle oscillographic reports detailing current, voltage, contact I/O, and protection element conditions during events
- Sequence-of-events recording that captures, time-tags, and stores 512 latest state changes of contact inputs, contact outputs, control points, and protections elements
- Voltage disturbance recording that provides information on voltage sags, swells and interruptions
- Fault locating function that indicates the fault type, currents and (when feeder impedance and length information are defined) fault location
- Broad operating temperature range: -40° to +85°C (-40° to +185°F)
- Type-certified to a wide range of electrical noise, temperature cycling, and seismic tests, as applicable to protective relays in utility and industrial applications

Test switch major features

- Two 30-pole STATES FMS-type test switch banks are supplied with each ELOCS
- Each relay contact input and output is double-switched to provide complete isolation
- Eight spare switch poles are available for owner use
- Switches are UL listed and CSA certified
- Clear covers allow pole markings to be viewed without removing covers

- Stud terminals and insulated ring-lugs provide secure internal connections

EasiLinc Setting Transfer Software major features

- Tabular interface organizes settings into convenient categories
- Library of Application Setting Files supports a wide variety of protection schemes
- Application Setting Files pre-define the vast majority of relay settings, including:
 - All logic settings
 - All event reporting, load profile and sequence-of-events record settings
 - All automation settings
- Print function documents all user settings on a single sheet
- Import/export functions simplify the deployment of settings to the field
- Setting transfer screen uploads relay settings with three mouse clicks

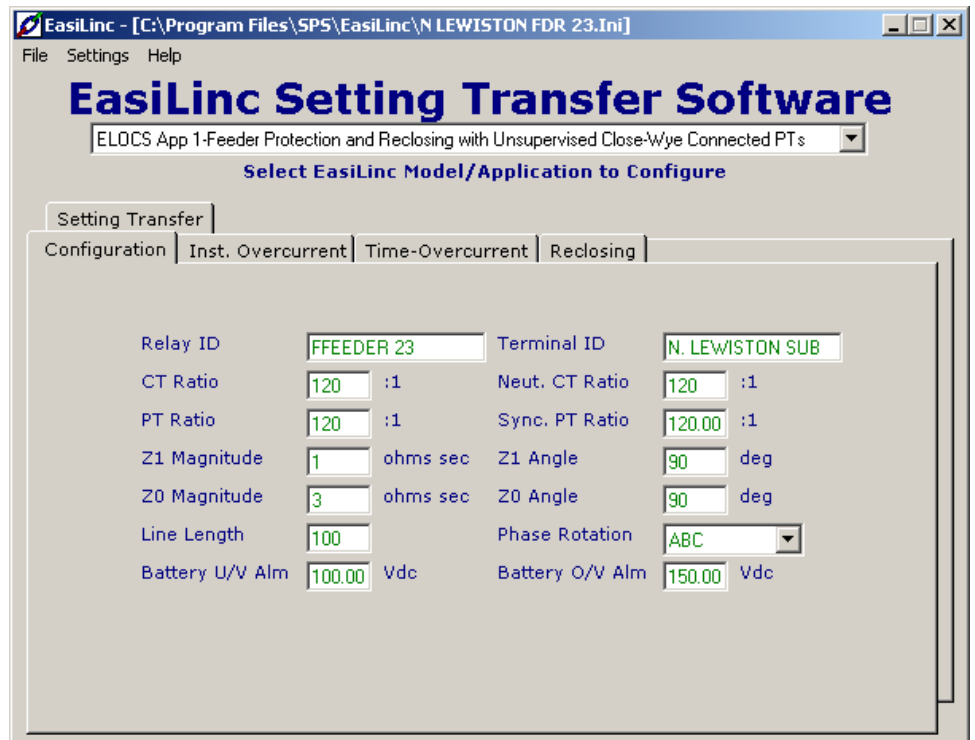

Mechanical drawings

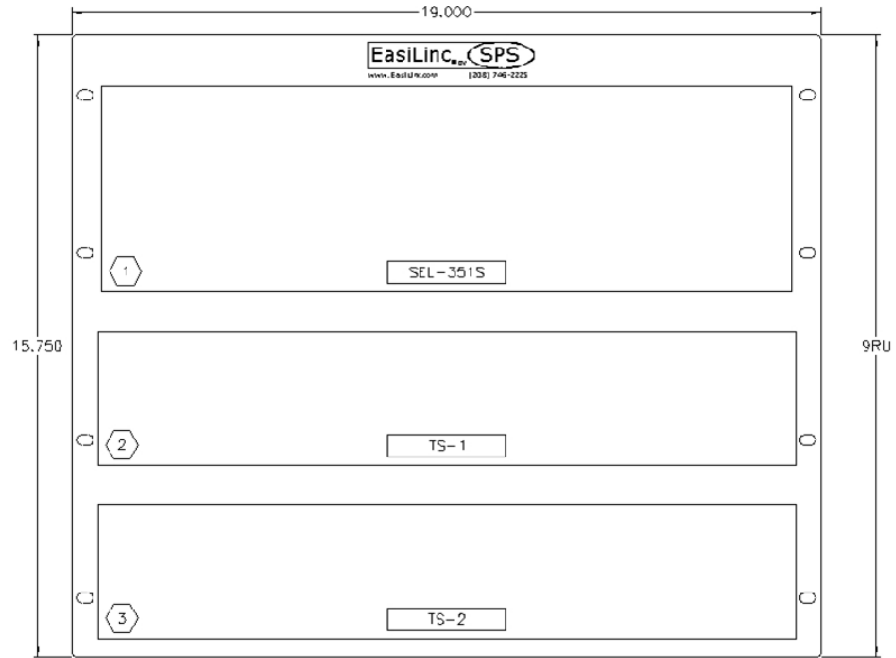

PANEL LAYOUT

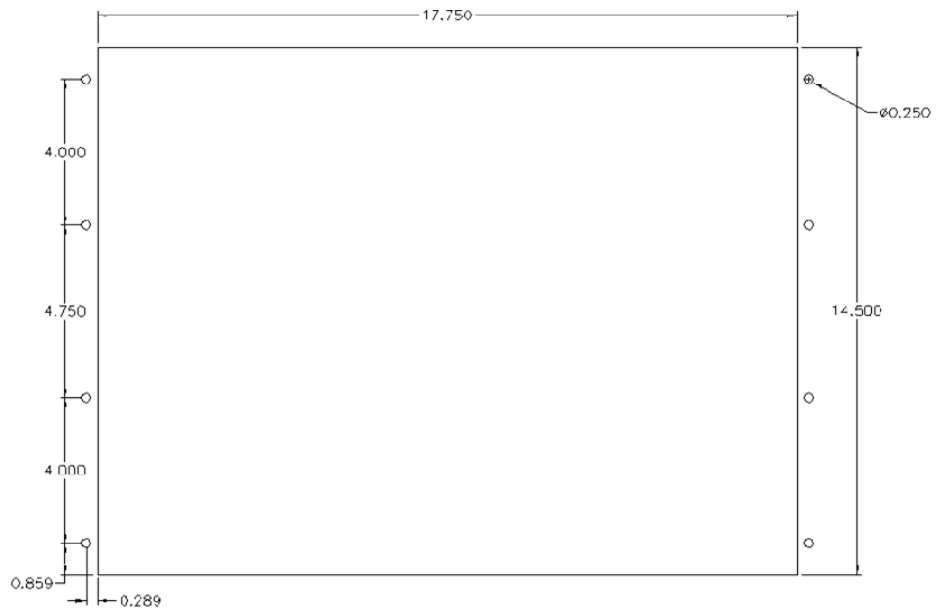

CUT & DRILL TEMPLATE

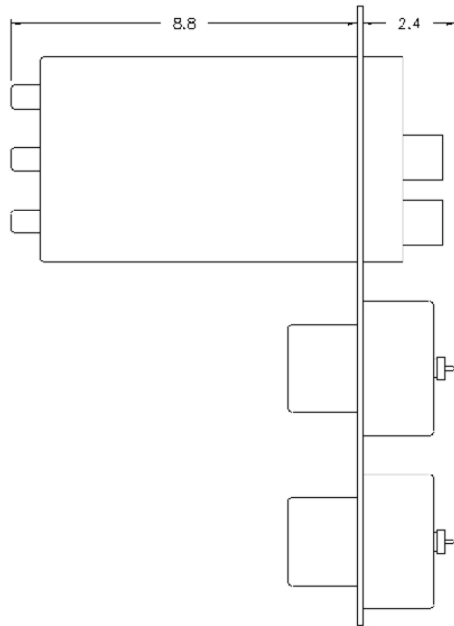

SIDE VIEW (STANDARD MOUNT)

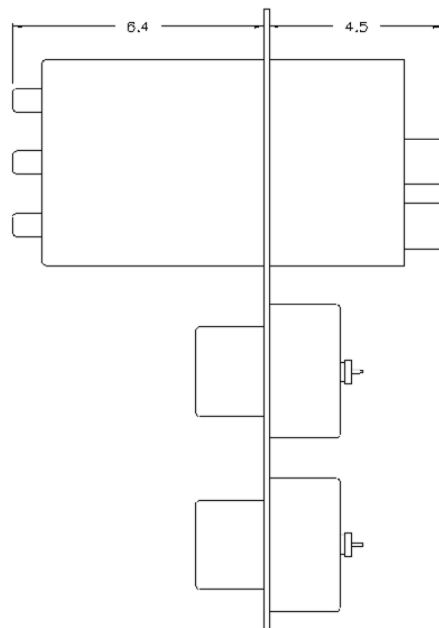

SIDE VIEW (PROJECTION MOUNT)

Learn More

HEADQUARTERS

POWER Engineers
 3940 Glenbrook Drive
 Hailey, Idaho 83333 USA
 PHONE: 208-788-3456
 FAX: 208-788-2082

CLARKSTON, WASHINGTON

POWER Engineers
 1300 16th Avenue, Suite 200
 Clarkston, WA 99403 USA
 PHONE: 509-758-6029
 FAX: 509-758-6145

www.easilinc.com

Guideform specification

Vendor shall supply a microprocessor-based protective relay pre-wired with test switches in a mounting panel no larger than 9 rack units and suitable for mounting in a 19" equipment rack or in an appropriate panel cutout. The protective relay shall be equipped with a front-panel user interface that permits local operator control of protection and reclosing functions. The protection module shall be supported by AC three-line and DC schematic diagrams for the appropriate application options. Schematics shall be included in .pdf, .dwg, and .dxf electronic formats for finalization by the owner. The protection module shall be supported by a PC software package and a library of application setting files. Each application setting file shall pre-configure relay contact input and output logic functions, event report and SER generation, reclosing logic (if needed), and shall include logic and settings to support future operation with substation HMI and paging solutions. The software shall provide a simple interface for the user to configure the remaining protection and reclosing settings and download all settings to the protective relay. The software shall support the storage, printing, and deployment of the installation settings.

ELOCS model numbers

ELOCS- _ _ _ _ _ - _ _ _ _ _
 a b c d e [Client Number]

Please contact your EasiLinc representative or POWER for your client number.

If your application requires:	Then Select:
Wye connected potential transformers: Delta connected potential transformers:	a = Y a = D
5 A secondary nominal current inputs: 1 A secondary nominal current inputs:	b = 5 b = 1
24Vdc/48Vdc Power Supply Rating: 48Vdc/125Vdc or 120Vac Power Supply Rating: 125Vdc/250Vdc or Vac Power Supply Rating:	c = 2 c = 3 c = 4
DC control input supply voltage:	d = 1 d = 2 d = 3 d = 4 d = 5 d = 6
Semi-flush mounting: Projection mounting:	e = S e = P

All brand or product names appearing in this document are the trademark or registered trademark of their respective holders.

Copyright POWER Engineers, Inc. 2009
 (All Rights Reserved)