

## ELXF5 DATASHEET

EasiLinc differential and overcurrent protection module  
For transformer protection

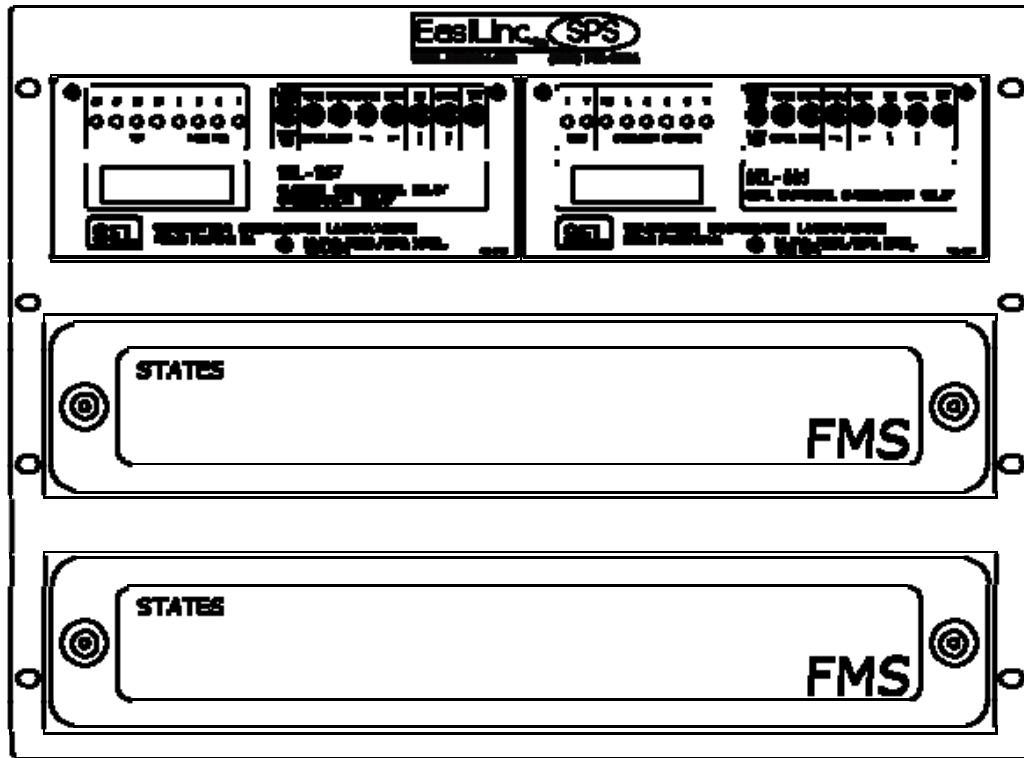

- SEL-587 and SEL-501-2 relays with pre-wired test-switches
- Perfect for retrofit or new construction projects
- Save design time using included schematics and wiring diagrams
- Use in 19" equipment rack or panel cutout
- For utility and industrial applications

## The ELXF5 protection module

The EasiLinc ELXF5 protection module offers a low-cost solution for transformer protection in a small, simple, easy to install package. The module includes one SEL-587 Relay and one SEL-501-2 Relay with appropriate test switches. These devices are pre-wired and installed in a mounting panel suitable for a 19" equipment rack or switchgear panel cutout. Also included are all the AC and DC application schematics you need to generate final construction prints quickly for your installation.

### Using the ELXF5, you:

- Reduce costs and complexity by using simple relays.
- Reduce space requirements by protecting more equipment per square foot of panel space.
- Reduce electrical design costs by using the provided AC and DC schematics.
- Reduce installation and commissioning costs with pre-wired and pre-tested modules.
- Reduce substation automation costs by using the standard control interface.
- Standardize your design, installation, operation, and maintenance procedures.
- Obtain the accuracy, reliability and availability benefits of high performance relays.
- Support accelerated deployment schedules by taking advantage of included design documents.

## Product applications

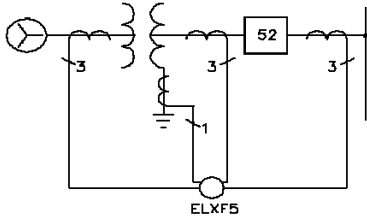

- Step-up transformer differential protection
- Primary phase and residual ground overcurrent protection
- Neutral overcurrent protection
- Backup phase and residual ground overcurrent protection

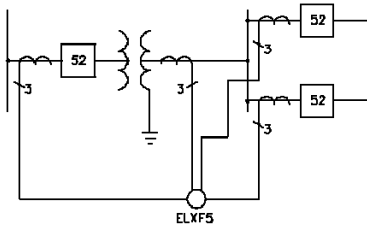

- Distribution transformer differential protection
- Bus phase and residual ground overcurrent protection
- Backup bus protection provided by upstream protection devices
- Phase and residual ground protection for two feeders

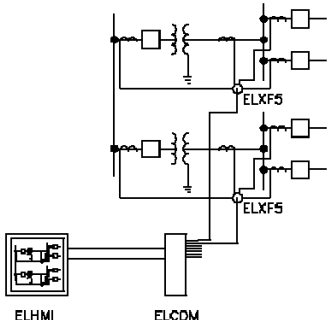

- Substation communication architecture using EasiLinc modules
- Communication architecture may be extended to central office locations
- Modular concept supports multi-stage projects
- Advanced notification solutions, including paging and e-mail are also available

## SEL- 587 Relay major features

- One three phase current differential element
- Two separate sets of phase, high-set, residual, and negative sequence instantaneous and time-overcurrent protection elements
- Adaptive phase overcurrent elements permit the relay to perform dependably in plant applications where fault currents can be very high
- Separate trip and close control of a breaker concurrent with lockout tripping
- Accurate metering functions for current
- Front-panel LCD display indicates metered values and text messages of relay, breaker and alarm conditions
- Event reporting that automatically captures and stores 10 most recent fifteen-cycle oscillographic reports detailing current, contact I/O and protection element conditions during events
- Broad operating temperature range: -40° to +85°C (-40° to +185°F)
- Type-certified to a wide range of electrical noise, temperature cycling, and seismic tests, as applicable to protective relays in utility and industrial applications

## SEL-501-2 Relay major features

- Two separate sets of phase, high-set, residual, and negative sequence instantaneous, and time-overcurrent protection elements
- Adaptive phase overcurrent elements permit the relay to perform dependably in plant applications where fault currents can be very high
- Controls each breaker with separate trip commands
- Accurate metering functions for current
- Front-panel LCD display indicates metered values and text messages of relay, breaker and alarm conditions
- Event reporting that automatically captures and stores 10 most recent fifteen-cycle oscillographic reports detailing current, contact I/O and protection element conditions during events

## Test switch major features

- Two 30-pole STATES FMS-type test switch banks are supplied with each ELXF5
- Each relay contact input and output is double-switched to provide complete isolation
- Four spare switch poles are available for owner use
- Switches are UL listed and CSA certified
- Clear covers allow pole markings to be viewed without removing covers
- Stud terminals and insulated ring-lugs provide secure internal connections

# Mechanical drawings

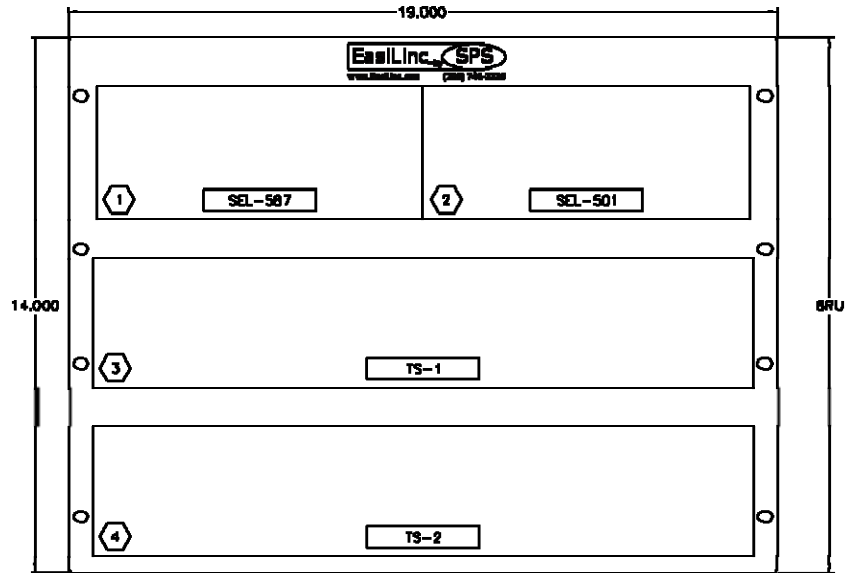

PANEL LAYOUT

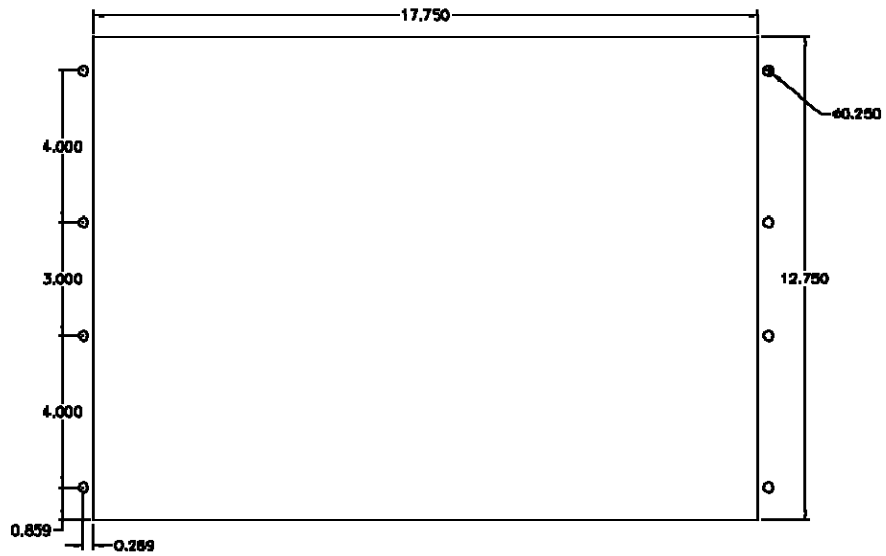

CUT & DRILL TEMPLATE

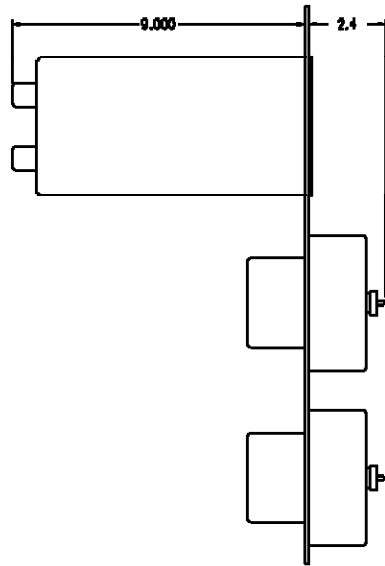

SIDE VIEW (STANDARD MOUNT)

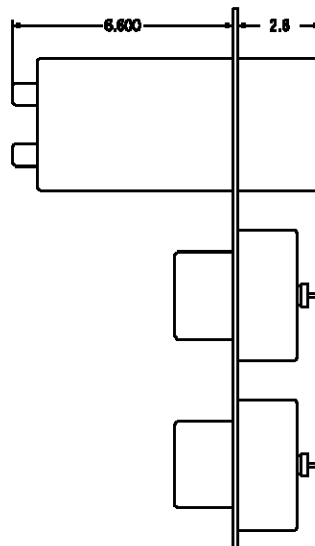

SIDE VIEW (PROJECTION MOUNT)

## Learn More

### HEADQUARTERS

POWER Engineers  
 3940 Glenbrook Drive  
 Hailey, Idaho 83333 USA  
 PHONE: 208-788-3456  
 FAX: 208-788-2082

### CLARKSTON, WASHINGTON

POWER Engineers  
 1300 16<sup>th</sup> Avenue, Suite 200  
 Clarkston, WA 99403 USA  
 PHONE: 509-758-6029  
 FAX: 509-758-6145

[www.easilinc.com](http://www.easilinc.com)

## Guideform specification

Vendor shall supply a microprocessor-based protective relay set that is pre-wired with test switches in a mounting panel no larger than 8 rack units and suitable for mounting in a 19" equipment rack or in an appropriate panel cutout. The functions of the relay set shall include a single differential current protection element and four overcurrent protection elements. Two of the four overcurrent protection elements shall use the same current transformer (CT) connections as the differential current protection element. The other two overcurrent elements shall be completely independent. The protection module shall be supported by AC three-line and DC schematic diagrams for the appropriate application options. Schematics shall be included in .pdf, .dwg, and .dxf electronic formats for finalization by the owner.

## ELXF5 model numbers

ELXF5- \_ \_ \_ \_ - \_ \_ \_ \_ \_ \_ \_ \_  
 a b c d [Client Number]

Please contact your EasiLinc representative or POWER for your client number.

If your application requires:	Then Select:
5 A secondary nominal current inputs:	a = 5
1 A secondary nominal current inputs:	a = 1
24Vdc/48Vdc Power Supply Rating:	b = 2
48Vdc/125Vdc or 120Vac Power Supply Rating:	b = 3
125Vdc/250Vdc or Vac Power Supply Rating:	b = 4
DC control input supply voltage:	c = 1
24Vdc	c = 2
48Vdc	c = 3
110Vdc	c = 4
125Vdc	c = 5
220Vdc	c = 6
250Vdc	
Semi-flush mounting:	d = S
Projection mounting:	d = P

All brand or product names appearing in this document are the trademark or registered trademark of their respective holders.

Copyright POWER Engineers, Inc. 2009  
 (All Rights Reserved)