

ELXFA DATASHEET

EasiLinc differential protection module
For transformer and bus protection

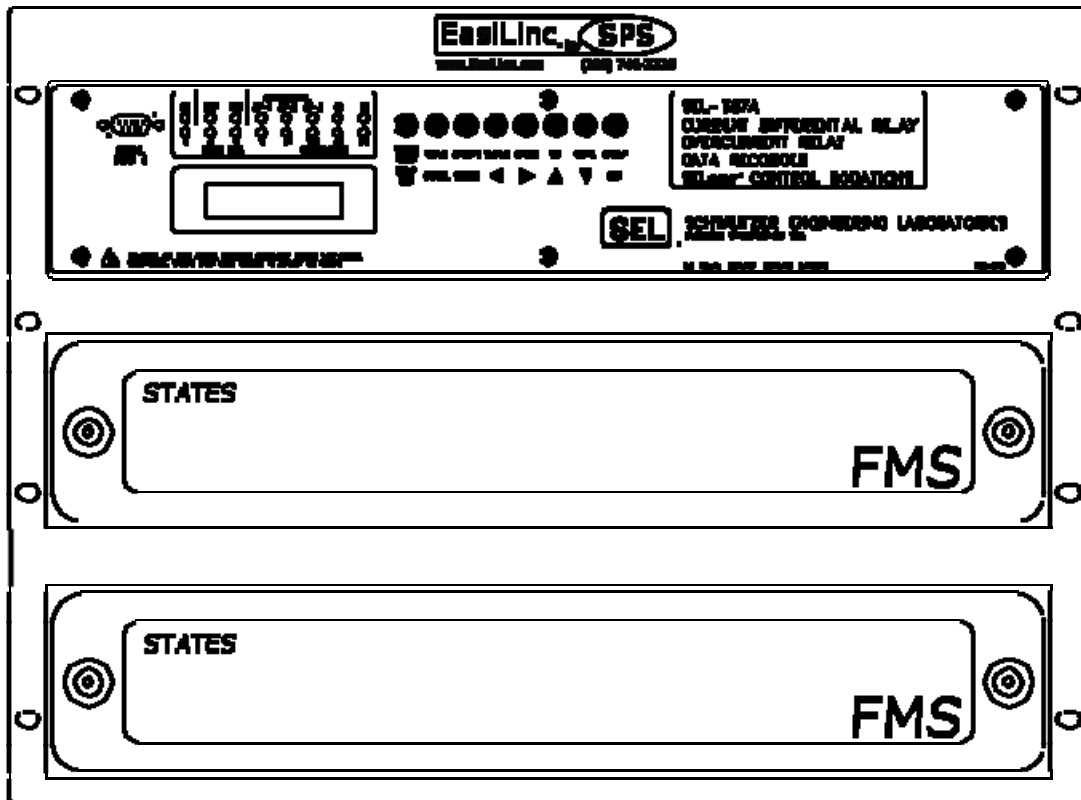

- SEL-387A Relay and all test-switches mounted and wired
- Perfect for retrofit or new construction projects
- Pre-wired design minimizes installation time and complexity, maximizes space utilization
- Standard test switch assignment improves schematic and wiring design efficiency
- Event recording, SER and communication functions active and configured
- Use in 19" equipment rack or panel cutout
- For two winding transformer protection applications

The ELXFA protection module

The EasiLinc ELXFA protection module simplifies your use of microprocessor-based relays for transformer protection. The module includes an SEL-387A Relay and appropriate test switches. These devices are pre-wired and installed in a mounting panel suitable for a 19" equipment rack or switchgear panel cutout. Also included are all the AC and DC application schematics you need to generate final construction prints quickly for your installation.

Using the ELXFA, you:

- Reduce electrical design costs by using the provided AC and DC schematics.
- Reduce installation and commissioning costs with pre-wired and pre-tested modules.
- Reduce substation automation costs by using the standard control interface.
- Standardize your design, installation, operation, and maintenance procedures.
- Obtain the accuracy, reliability and availability benefits of a high performance relay.
- Support accelerated deployment schedules by taking advantage of included design documents.

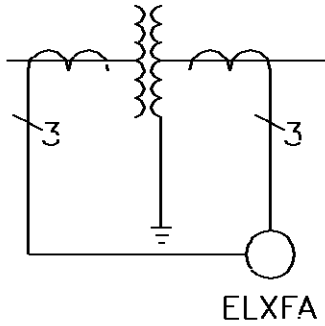

Product applications

- Two winding transformer differential protection

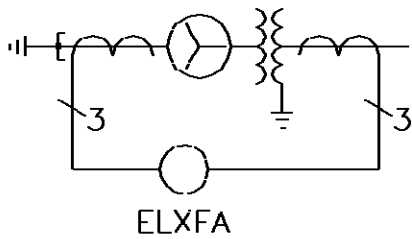

- Unit overall differential protection

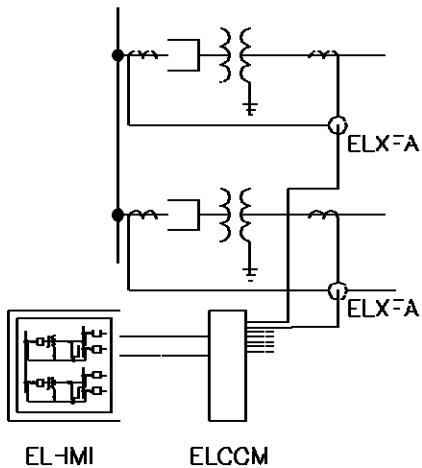

- Substation communication architecture using EasiLinc modules
- Architecture may be extended to central office locations
- Modular concept supports multi-stage projects
- Advanced notification solutions, including paging and e-mail are also available

SEL- 387A Relay major features

- Sensitive two-winding current differential protection with programmable single- or dual-slope percentage restraint, supervised by a choice of second- and fourth-harmonic blocking or restraint elements, plus fifth-harmonic and dc blocking elements
- Individual winding overcurrent protection with one instantaneous and one time overcurrent element each phase, residual or negative sequence currents
- Through-fault recording and monitoring for use in control equations or manual monitoring
- Restricted Earth Fault (REF) logic for sensitive protection of grounded wye windings
- Accurate metering functions for current, DC battery voltage and demand
- Front-panel LCD display indicates metered values and text messages of relay, breaker and alarm conditions
- Event reporting that automatically captures and stores 23 most recent eleven-cycle oscillographic reports detailing current, voltage, contact I/O, and protection element conditions during events
- Sequence-of-events recording that captures, time-tags and stores 512 latest state changes of contact inputs, contact outputs, control points, and protections elements
- Broad operating temperature range: -40° to $+85^{\circ}\text{C}$ (-40° to $+185^{\circ}\text{F}$)
- Type-certified to a wide range of electrical noise, temperature cycling, and seismic tests, as applicable to protective relays in utility and industrial applications

Test switch major features

- Two 30-pole STATES FMS-type test switch banks are supplied with each ELXFA
- Each relay contact input and output is double-switched to provide complete isolation
- Eight spare switch poles are available for owner use
- Switches are UL listed and CSA certified
- Clear covers allow pole markings to be viewed without removing covers
- Stud terminals and insulated ring-lugs provide secure internal connections

Mechanical drawing

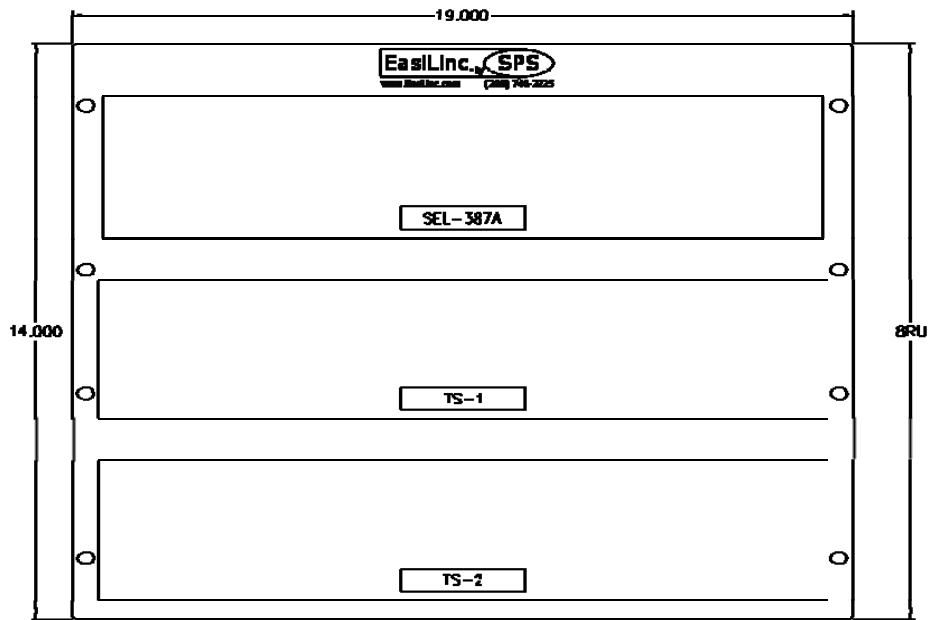

PANEL LAYOUT

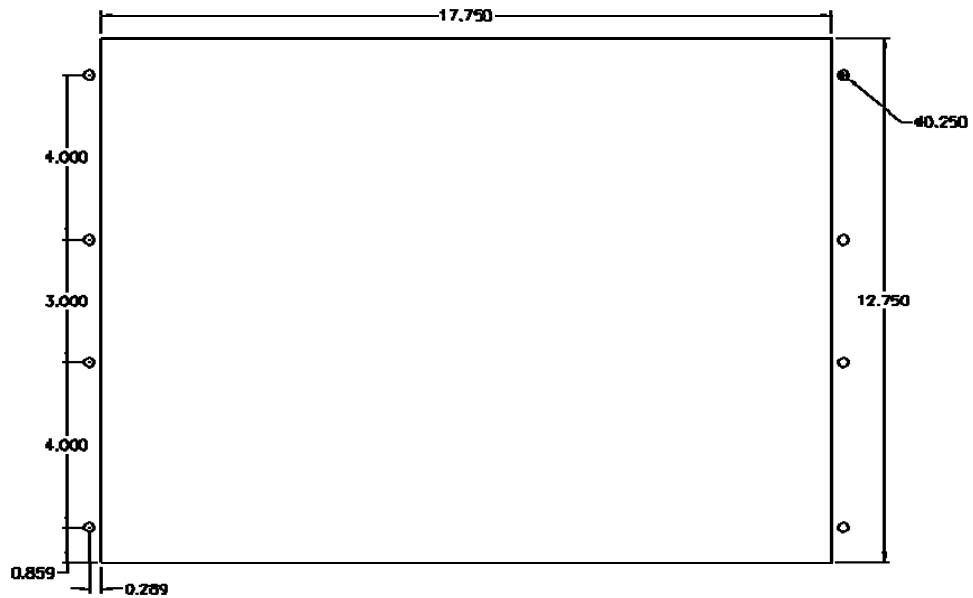

CUT & DRILL TEMPLATE

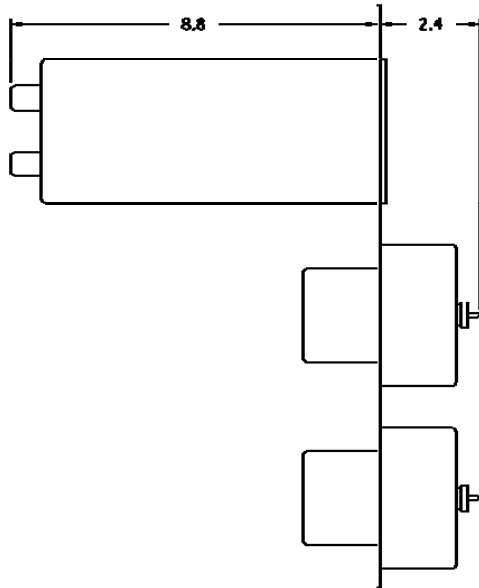

SIDE VIEW (STANDARD MOUNT)

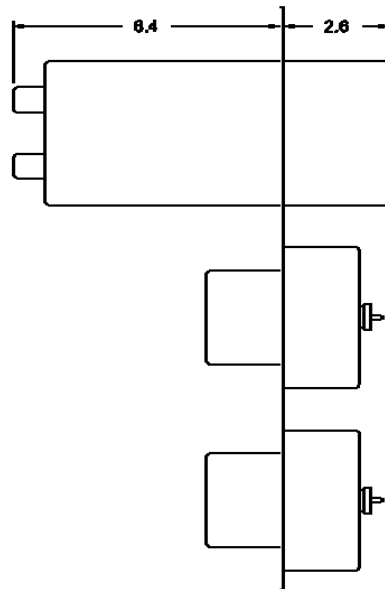

SIDE VIEW (PROJECTION MOUNT)

Learn More

HEADQUARTERS

POWER Engineers
 3940 Glenbrook Drive
 Hailey, Idaho 83333 USA
 PHONE: 208-788-3456
 FAX: 208-788-2082

CLARKSTON, WASHINGTON

POWER Engineers
 1300 16th Avenue, Suite 200
 Clarkston, WA 99403 USA
 PHONE: 509-758-6029
 FAX: 509-758-6145

www.easilinc.com

Guideform specification

Vendor shall supply a microprocessor-based protective relay for protection of two winding transformers and a variety of bus configurations. Relay shall provide percentage differential, overcurrent and restricted earth fault protection functions to be utilized by customizable logic programming. Non-protection functions shall include as a minimum: self testing/alarming, metering, remote controls, communications interface, multiple settings groups and event reporting. The relay must be pre-wired with test switches in a mounting panel no larger than 8 rack units and suitable for mounting in a 19" equipment rack or in an appropriate panel cutout. Each relay input and output shall be wired with test switches on the positive and negative terminal in order to accomplish total isolation for convenience of installation, testing and design standardization. For maximum flexibility of design, all relay inputs/outputs shall be wired out to test switches. The protective relay shall be equipped with a front-panel user interface. The protection module shall be supported by AC three-line and DC schematic diagrams for the various application options. Schematics shall be included in .pdf, .dwg, and .dxf electronic formats for finalization by the owner.

ELXFA model numbers

ELXFA- _ _ _ _ - _ _ _ _ _
 a b c d [Client Number]

Please contact your EasiLinc representative or POWER for your client number.

If your application requires:	Then Select:
5 A secondary nominal current inputs:	a = 5
5 A secondary nominal w/neutral inputs :	a = 6
1 A secondary nominal current inputs:	a = 1
1 A secondary nominal w/neutral inputs :	a = 2
24Vdc/48Vdc Power Supply Rating:	b = 2
48Vdc/125Vdc or 120Vac Power Supply Rating:	b = 3
125Vdc/250Vdc or Vac Power Supply Rating:	b = 4
DC control input supply voltage:	c = 1
24Vdc	c = 2
48Vdc	c = 3
110Vdc	c = 4
125Vdc	c = 5
250Vdc	
Semi-flush mounting:	d = S
Projection mounting:	d = P

All brand or product names appearing in this document are the trademark or registered trademark of their respective holders.

Copyright POWER Engineers, Inc. 2009
 (All Rights Reserved)